

 深圳市汇科源电子科技有限公司 Shenzhenshi Huikeyuan Electronic Tech.co., LTD		REVISION (版本)	A0
		DATE (日期)	2026.03.19
PART NUMBER (产品编号)	A100C14-240006250 60601	CUSTOMER NAME AND MODEL (客户名称和型号)	

SPECIFICATION FOR APPROVAL

产 品 承 认 书

CUSTOMER / 客 户: _____

CUSTOMER MODEL NO. / 客户型号: _____

SAMPLE NO. / 样品单号: _____

SERIES PRODUCTS / 产品系列: A100-150W-GAN 系列

PRODUCT NAME / 产品名称: GaN Power Supply 氮化镓电源供应器

OUR MODEL NO. / 机种型号: A100C14-240006250 60601

Color / 颜色: Black/黑色

DATE / 日期: 2026.03.19

CUSTOMER APPROVED SIGNATURE		
客户确认		

Designed by	Checked by	Approved by
制 作	审 核	批 准
张繁	黄勇	

Please to sign back after you confirm!

承认书确认后请回签一份!

 深圳市汇科源电子科技有限公司 Shenzhenshi Huikeyuan Electronic Tech.co., LTD		REVISION (版本)	A0
		DATE (日期)	2026.03.19
PART NUMBER (产品编号)	A100C14-240006250 60601	CUSTOMER NAME AND MODEL (客户名称和型号)	

Rev. List/版本目录			
Rev. /版本	Date/日期	Description/描述	Design/制订
A0	2026.03.19	New Rev. /新版本	

Content/目录

1.	Scope (适用范围)	4
2.	Interface Type (接口类型)	4
3.	Quote Criterion (引用标准)	4
4.	Electrical Characteristic (电气特性)	4
5.	Input Characteristics (输入特性)	5
5.1.	Rated Input Voltage (额定输入电压)	5
5.2.	Input Voltage Range (输入电压范围)	5
5.3.	Rated Frequency (输入频率)	5
5.4.	Empty loaded wasting (空载功耗)	5
5.5.	Frequency Range (输入频率范围)	5
5.6.	Steady AC Current (AC 输入电流)	5
5.7.	Input Inrush Current (输入浪涌电流)	5
6.	Output Characteristics (输出特性)	6
6.1.	Rated Output Voltage (输出额定电压 额定电流)	6
6.2.	Rated Power (额定功率)	6
6.3.	Output Ripple and Noise (输出纹波、噪音)	6
6.4.	Average Efficiency (平均效率)	7
6.5.	Protection (保护)	7
6.5.1.	Over Current Protection (过流保护)	7
6.5.2.	Short Circuit Protection (短路保护)	7
6.5.3.	Over voltage protection (过压保护)	7
6.5.4.	Over heating protection (过热保护)	7
7.	Reliability Items (信赖性项目)	7
7.1.	Electrostatic Discharge (静电)	7
7.2.	Hi-Pot Test (高压测试)	8
7.3.	Insulation Resistance (绝缘电阻)	8
7.4.	Leakage Current (泄漏电流)	8
7.5.	Temperature Rise (温升)	8

 深圳市汇科源电子科技有限公司 Shenzhenshi Huikeyuan Electronic Tech.co., LTD		REVISION (版本)	A0
		DATE (日期)	2026.03.19
PART NUMBER (产品编号)	A100C14-240006250 60601	CUSTOMER NAME AND MODEL (客户名称和型号)	

8. Environmental Requirement (环境要求)	8
8.1. Operating Temperature (工作温度)	8
8.2. Storage Temperature (储藏温度)	8
8.3. Operating Humidity (工作湿度)	8
8.4. Storage Humidity (储藏湿度)	8
9. Mechanical Requirement (机械要求)	9
9.1. Input plug type (输入插头类型)	9
9.2. Drop Test (跌落试验)	9
9.3. Salty Fog Test for Metal Part (五金件盐雾实验)	9
10. Mechanical Characteristics (机械性能)	9
10.1.Appearance (外观)	9
10.2.Case/Resin Materials (外壳材质)	9
10.3.Vibration test (振动实验)	9-10
11. Environmental Performances (环境性能)	10
11.1.Operating at the Lower temperature (低温工作实验)	10
11.2.Operating at the High Temperature (高温工作实验)	10
11.3.Storage at the Lower Temperature(低温放置)	10
11.4.Storage at the Higher Temperature (高温放置)	10
11.5.Storage at High Temperature and High Humidity (高温高湿度放置)	10
11.6.Storage at low Temperature and Low Humidity (低温低湿度放置)	11
12. Photograph of the Product (产品外观图)	11

 深圳市汇科源电子科技有限公司 Shenzhenshi Huikeyuan Electronic Tech.co., LTD		REVISION (版本)	A0
		DATE (日期)	2026.03.19
PART NUMBER (产品编号)	A100C14-240006250 60601	CUSTOMER NAME AND MODEL (客户名称和型号)	

1. Scope (适用范围)

The specification shall be applied to the field of Medical equipment
 本规范应适用于医疗设备领域。

2. Interface-Type(接口)

Type: 航空头 4 针/Aviation head 4-pin



3. Quote Criterion (引用标准)

3.1 Safety:accord with (安规:符合标准)

- ①IEC 60601-1:2005+AMD1:2012+ADM: 2020
- ②EN 60601-1: 2006/A2: 2021

3.2 EMI STANDARD (EMI 标准)

- ①ICE60601-1-2:2014+A1:2020
- ②EN60601-1-2: 2-15+A1:2021 47 CFR FCC Part 15, Subpart B, ANSI C63.4-2014 EN 50498: 2010

4. Electrical Characteristic (电气特性)

Test Circuit (测试电路)

If the test is to be made on a specified circuit, be sure to use the following circuit.
 (无特殊规定的情况下依照下面的电路进行测试, A1、A2 为电流表.)

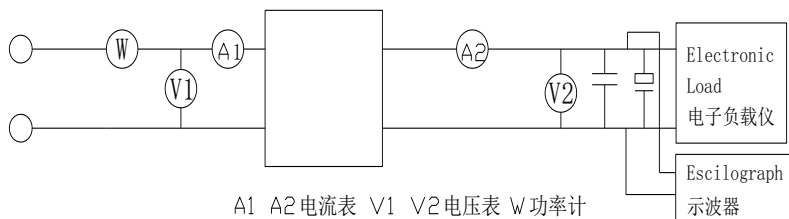

 深圳市汇科源电子科技有限公司 Shenzhenshi Huikeyuan Electronic Tech.co., LTD		REVISION (版本)	A0
		DATE (日期)	2026.03.19
PART NUMBER (产品编号)	A100C14-240006250 60601	CUSTOMER NAME AND MODEL (客户名称和型号)	

5. Input Characteristics (输入特性)

5.1. Rated Input Voltage (额定输入电压)

It is normal for 100Vac to 240Vac input AC voltage.
(额定输入交流 100V~240V)

5.2. Input Voltage Range (输入电压范围)

The adapter shall operate from 90to 264Vac and the range switching is unnecessary.
(输入电压范围交流 90V~264V)

5.3. Rated Frequency (输入频率)

It is normal for 50Hz or 60Hz and single phase.
(输入频率 50Hz/60Hz)

5.4. Empty loaded wasting(空载功耗)

The input power is 210mW(0.21W) or less in empty loaded.
输入空载功耗小于 210mW(0.21W)

5.5. Frequency Range (输入频率范围)

The adapter shall operate with an input frequency from 47Hz to 63Hz.
(输入频率范围 47Hz~63Hz)

5.6. Steady AC Current (AC 输入电流)

Maximum steady state input current is 2.5A (Max) Measured at 90Vac input and maximum load.
(90V 满载时输入电流 2.5A 最大)

5.7. Input Inrush Current (输入浪涌电流)

With cold starting, the Input Inrush current should less than 80A.
(电源启动时输入涌浪电流小于 80A)

 深圳市汇科源电子科技有限公司 Shenzhenshi Huikeyuan Electronic Tech.co., LTD		REVISION (版本)	A0
		DATE (日期)	2026.03.19
PART NUMBER (产品编号)	A100C14-240006250 60601	CUSTOMER NAME AND MODEL (客户名称和型号)	

6. Output Characteristics (输出特性)

6.1. Rated Output Voltage Current (输出额定电压电流)

Model 型号	5.1 Output Voltage 输出电压	5.1 Min Load 最小负载	5.1 Output Current 输出电流	5.1 Load Regulation 负载调整	5.1 Line Regulation 线性调整	5.1 Output Voltage Range 输出电压范围	5.2 Rated Power 额定功率	5.3 Ripple/Noise (p-p) 纹波噪声	5.4 average efficiency 平均效率	5.5.1 Over Current Protection 过流保护
A100-240006250-C14	24V	0A	6.25A	±5%	±1%	22.8V-25.2V	150W	300mV Max	89% Min	9A Max

6.2. Rated Power (额定功率)

This adapter is capable to support Rated Max Power continuously at all specified conditions. Note: the test shall be made under the following conditions, unless otherwise specified: Ambient Temperature 25°C, Relative Humidity 35~85%RH Air Pressure 86~106kPa

(不同状态下输出额定最大功率, 在无特别指定条件下,测试温度为 25°C、湿度为 35~85%RH、气压为 86~106kPa)

6.3. Output Ripple and Noise (输出纹波、噪音)

6.3.1 AC Input 115V/60Hz,230V/50Hz. Output ripple voltage is less Measured methods:Performed by 20MHz bandwidth in oscilloscope. Applied 0.1uF ceramic capacitor and 10uF electrolytic capacitor across output connector terminals Measured at the end of DC cable.

(AC 输入 115V/60Hz,230V/50Hz. 输出端并 0.1uF 与 10uF 电容, 限制示波器带宽 20MHz 时)

6.3.2 Turn on delay time/启动延迟时间:

3Second Max.at 115Vac input and output Max.load.

当输入 115Vac 和输出最大负载时, 最大启动时间为 3S.

6.3.3 Rise time/上升时间:

200 mS Max.at 115Vac input and output Max load.

当输入 115Vac 和输出最大负载时最大时间为 200 mS.

6.3.4 Hold up time/保持时间:

29 mS Min.at 115Vac input and output Max.Load.

当输入 115Vac 和输出最大负载时, 最小保持时间为 29 mS .

 深圳市汇科源电子科技有限公司 Shenzhenshi Huikeyuan Electronic Tech.co., LTD		REVISION (版本)	A0
		DATE (日期)	2026.03.19
PART NUMBER (产品编号)	A100C14-240006250 60601	CUSTOMER NAME AND MODEL (客户名称和型号)	

6.4. Average Efficiency (平均效率)

Measured at 115Vac and 230Vac input voltage, maximum load .DOE or ERP (level VI), All data was measurement at pcb end.

在输入电压 115Vac -230Vac, 输出最大负荷下, 适配器工作效率满足 DOE 或者 ERP (6 级), 所有数据在 pcb 板端结束处测量。

6.5. Protection (保护)

6.5.1. Over Current Protection (过流保护)

Output over current protection current is limited and less than the maximum value
输出过流保护电流被限制且小于最大值

6.5.2. Short Circuit Protection (短路保护)

When the output is shorted, the input power is reduced and will not damage, there will be (burp state). When the fault condition is removed, the product will be automatically returned to normal

当输出短路时,产品输入功率降低且不会损伤,会有(打嗝的状态).当短路情况解除后,产品将会自动恢复正常

6.5.3. Over voltage protection (过压保护)

The power supply will auto recovered when faults remove 120%~150%.

当输出电压超过额定电压的 120%~150%时, 电源将保护, 故障排除后能恢复正常工作.

6.5.4. Over heating protection (过热保护)

When the output power exceeds the usage limit or the product overheats abnormally, the power supply automatically derates the output power according to the temperature or is protected by the temperature. After the fault is rectified, the power supply returns to normal operation

当输出功率超额使用时或产品异常过热时, 电源将智能根据温度降额输出功率, 或温度保护, 故障排除后能恢复正常工作

7. Reliability Items (信赖性项目)

7.1. Electrostatic Discharge (静电)

At 150pF: 330Ω, for each point, 10 shots of direct discharge or air discharge. (1 MΩ/SHOT), have no malfunction. Direct discharge: ±8kV, Air discharge: ±15kV

(在接触放电±8kV 和空气中放电±15kV 模式下,各处分别放电 10 次无误动作)

 深圳市汇科源电子科技有限公司 Shenzhenshi Huikeyuan Electronic Tech.co., LTD		REVISION (版本)	A0
		DATE (日期)	2026.03.19
PART NUMBER (产品编号)	A100C14-240006250 60601	CUSTOMER NAME AND MODEL (客户名称和型号)	

7.2. Hi-Pot Test (高压测试)

After AC 3000V1min between input plug-DC plug. cutoff current 5mA, the adapter have no failures like damages, arch, insulation damage etc. (at 25° C)

在 25° C 环境下, AC 输入插头与 DC 插头之间加 AC3000V 1 分钟, 电流 5mA 最大, 适配器无损伤、电弧放电、绝缘破坏等异常。)

7.3. Insulation Resistance (绝缘电阻)

At 25° C after DC 500V 1min between input plug- DC plug, insulation resistance 7MΩ/min)

(在 25° C 环境下, AC 输入插头与 DC 插头之间输入 DC500V1 分钟后绝缘阻抗在 7MΩ 以上)

7.4. Leakage Current (泄漏电流)

0.25mA maximum, at nominal AC input voltage and frequency

(额定交流输入时泄漏电流不得超过 0.25mA)

7.5. Temperature Rise (温升)

At 25°C with the rated input 100-240Vac charged to the primary a rated load on the secondary ,every parts of the case surface rise 71°C or less,

(在常温 25°C 下输入端施加 100-240Vac 电压, 输出额定负载的状态下, 机壳温度小于 71°C。)

8. Environmental Requirement (环境要求)

8.1. Operating Temperature (工作温度)

-10°C TO 40°C Full load, Normal operation. 满载, 正常工作.

8.2. Storage Temperature (储藏温度)

-25°C TO +70°C With package/带外壳

8.3. Operating Humidity (工作湿度)

5%(0°C)~90%(40°C),RH,72Hrs,Full load, Normal operating.

5%(0°C)~90%(40°C), 湿度 72 小时, 满载, 正常工作

8.4. Storage Humidity (储藏湿度)

5% ~ 95% RH. Non-condensing

 深圳市汇科源电子科技有限公司 Shenzhenshi Huikeyuan Electronic Tech.co., LTD		REVISION (版本)	A0
		DATE (日期)	2026.03.19
PART NUMBER (产品编号)	A100C14-240006250 60601	CUSTOMER NAME AND MODEL (客户名称和型号)	

9. Mechanical Requirement (机械要求)

9.1. Input plug type (输入插头类型)

IEC-320-C14

9.2. Drop Test (跌落试验)

From 100cm height to the most likely to cause adverse results to the horizontal position of the surface drop test bed three times, the adapter in addition to surface scratches, it should be no dysfunction can cause the adapter and other potentially the harm. (Horizontal surface of the test rig shall be composed of at least 13mm thick hardwood installed in two layers of plywood, each layer of plywood thickness 19-20mm, and then placed on a cement base or equivalent on the ground inelastic)

(从 100cm 高处、以可能对其造成最不利结果的位置跌落至水平表面试验台 3 次，适配器除表面有擦伤外，应该没有任何功能障碍和其他方面能导致适配器产生潜在的危害。(水平表面试验台应是由至少 13mm 厚的硬木安装在两层胶合板上组成，每一层胶合板的厚度为 19-20mm，然后放在一水泥基座上或等效的无弹性的地面上)

9.3. Salty Fog Test for Metal Part (五金件盐雾实验)

Experiment condition, Salty water thickness: 5%, Equipment Temperature: 35 ~ 40 °C ,put the adapter(unpacking)in the test equipment for 24h, after 24h recovery at 25°C checking the appearance, the metal parts have no erode and rust.

(盐雾试验要求：调制（工业盐）盐水的浓度为 5%，设备温度设置为 35~40℃，适配器不包装，放入盐雾试验设备中持续喷雾 24 小时，试验结束后取出，在常温下搁置 24 小时，再检查适配器外观；要求外露金属及电镀件不生锈。)

10. Mechanical Characteristics (机械性能)

10.1. Appearance (外观)

Visual inspection the case have no visual abnormality, no obvious nick, burr and other mechanical damage, outer metal have no rust. Use limit sample to check for any failures.

(目视检查，无外观异常，表面无明显划痕、毛刺及其它机械损伤，外露金属部分无锈，其他限度根据样品确认。)

10.2. Case/Resin Materials (外壳材质)

Flame resistance applies to UL94-V1
(耐燃性遵循 UL94-V1)

10.3. Vibration test (振动实验)

The amplitude is 25.4mm, the frequency is 4.5Hz, the speed is 270 revolutions per 53 minutes, and the

 深圳市汇科源电子科技有限公司 Shenzhenshi Huikeyuan Electronic Tech.co., LTD		REVISION (版本)	A0
		DATE (日期)	2026.03.19
PART NUMBER (产品编号)	A100C14-240006250 60601	CUSTOMER NAME AND MODEL (客户名称和型号)	

vibration frequency is 14200 times. When the vibration is half done, rotate the goods horizontally by 90 ° or 180 ° and continue to vibrate. After the test, there are no abnormalities

(振幅为 25.4mm 频率 4.5Hz 转速 270 转 53 分, 振动次数 14200 次. 当振完一半时将货物水平旋转 90° 或 180° 后继续振动, 试验后测试无异常)

11. Environmental Performances(环境性能)

11.1. Operating at the Lower temperature (低温工作实验)

At -10±2°C, with the rated voltage 110-240Vac charged to the primary and unloaded and full load on the secondary, no abnormality in electric and mechanical characteristic, after 2 hours recovery at the room temperature.

(环境温度 -10±2°C, 在输入端施加额定电压 110-240Vac 输出端无负荷与满载状态下, 试验 2 小时, 无特性异常)

11.2. Operating at the High Temperature (高温工作实验)

At 40±2°C, with the rated voltage 110-240Vac charged to the primary and unloaded and full load on the secondary. No abnormality in electric and mechanical characteristic after 2 hours recovery at the room temperature.

(环境温度 40±2°C, 在输入端施加额定电压 110-240Vac 输出端无负荷与满载状态下, 试验 2 小时, 无特性异常)

11.3. Storage at the Lower Temperature (低温放置)

At -25±2°C, test of non-operated, No abnormality in electric and mechanical characteristic after 2 hours recovery at the room temperature.

(在 -25±2°C 非工作状态下进行试验, 试验后常温放置 2 小时后测试无异常)

11.4. Storage at the Higher Temperature (高温放置)

At 70±2°C, test of non-operated, No abnormality in electric and mechanical characteristic after 2 hours recovery at the room temperature.

(在 70±2°C 非工作状态下进行试验, 试验后常温放置 2 小时后测试无异常)

11.5. Storage at High Temperature and High Humidity (高温高湿度放置)

At 40±2°C, 90~95%RH, test of operating 48 hours, no abnormality in electric and mechanical characteristic, after 4 hours recovery at the room temperature.

(在 40°C ±2°C, 90~95%RH, 非工作状态试验持续 48H, 试验后常温放置 4 小时测试特性无异常)

 深圳市汇科源电子科技有限公司 Shenzhenshi Huikeyuan Electronic Tech.co., LTD		REVISION (版本)	A0
		DATE (日期)	2026.03.19
PART NUMBER (产品编号)	A100C14-240006250 60601	CUSTOMER NAME AND MODEL (客户名称和型号)	

11.6. Storage at low Temperature and Low Humidity (低温低湿度放置)

At $-10^{\circ}\text{C} \pm 2^{\circ}\text{C}$, 10%~40%RH, test of operating 48hours, no abnormality in electric and mechanical characteristic, after 4hours recovery at the room temperature.

(在 $-10^{\circ}\text{C} \pm 2^{\circ}\text{C}$, 10%~40%RH, 非工作状态试验持续 48H, 试验后常温放置 4 小时测试特性无异常)

12. Photograph of the Product (产品外观图)

12.1 Enclosure/外壳:

The power supply size: L152x W69x H31mm; 电源尺寸: 长 146.0×宽 59.0×高 28.5mm;

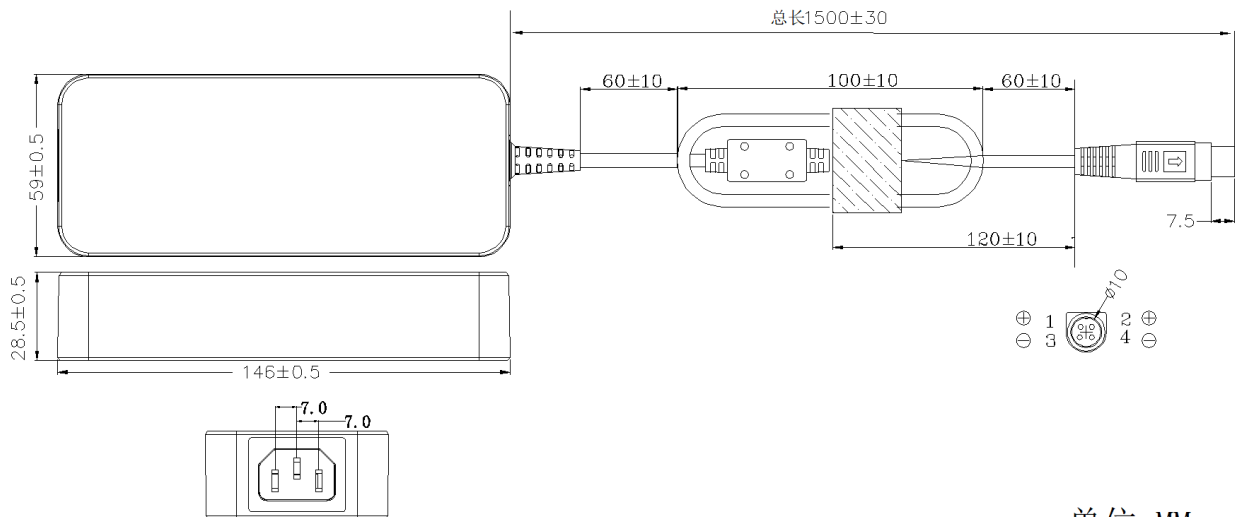

单位:MM